

## Pneumatic Nailer Type W 25-826 E

The compact and well balanced nailer drives corrugated fasteners type W Maxi in length from 18 to 25 mm. It satisfied a multitude of fastening requirements and is the perfect solution when fastening butt and corner joints.



### Popular applications:

Butt and corner jointing, framing,  
truss building, prefabricated house building

Length: 415 mm  
Width: 95 mm  
Height: 315 mm

### Technical data

Type description:	<b>W 25-826 E</b> Standard
Article code:	12100332
Magazine type :	Top loader
Safety:	Single actuation
Fastener type:	Type W Maxi
Magazine capacity:	100
Fasteners per strip:	2 x 40
Operating pressure:	6 – 8.5 bar
Max. operating pressure:	8.5 bar
Air consumption/operation:	2.6 litre / 6 bar
Inner hose diameter:	Ø 9 mm LW recommended
Emission sound pressure level at the workstation:	L pA, 1s, d= 82 dB
Single-shot emission sound pressure level:	L WA, 1 s,d= 95 dB
Weight:	3.7 kg

The vibration as per document no. CEN/TC 255 WG 1 N 47.3 is 3.5 m/s<sup>2</sup>.

**Extras supplied with the nailer:** Operating instructions, spare parts list, service instructions, silencer

Subject to technical modifications.

All BeA pneumatic tools can be jig-mounted  
We supply the necessary accessories and equipments.



This tool conforms to the EG Directive  
for Machinery (89/392 EWG)

Product leaflet 826 E

## Pneumatic Nailer Type W 25-826 E

Corrugated fasteners Type W



BeA Deutschland  
Befestigungstechnik  
P.O.Box 14 80  
D-22904 Ahrensburg  
Phone: +49 (0) 4102 78-0  
Fax: +49 (0)4102 78-250  
www.bea-group.com  
e-mail: [info@bea-group.com](mailto:info@bea-group.com)

a division of  
Joh. Friedrich Behrens AG

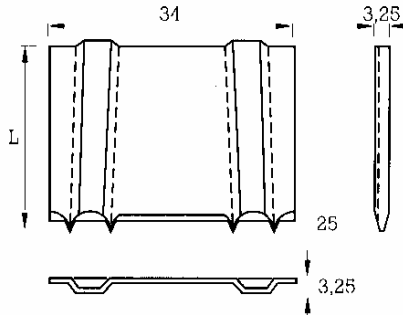

Description	L = Length mm
W 25 BK Maxi	25

**Explanations:**

NK = galvanized steel	BK = bright steel	LM = aluminium	HZ = resin coated
NKS = galvanized steel, extra hard	BKS = bright steel, extra hard	NR = stainless steel, material. 1.4401	DP = divergent point
NKH = galvanized steel, hard	MS = brass	RF = rust resistant, material 1.4301	SA = step cut